

# Modernization of a Swiss MBT-Plant with SCHUBIO®-Process

III International Symposium MBT & MRF  
12.-14.05.2009, Hanover



Dipl.-Ing. Reinhard Schu  
Dipl.-Biol. Kirsten Schu  
SCHU AG Schaffhauser Umwelttechnik  
Schaffhausen, Switzerland



**SCHU AG**  
Schaffhauser Umwelttechnik

# Development of SCHUBIO® - Process

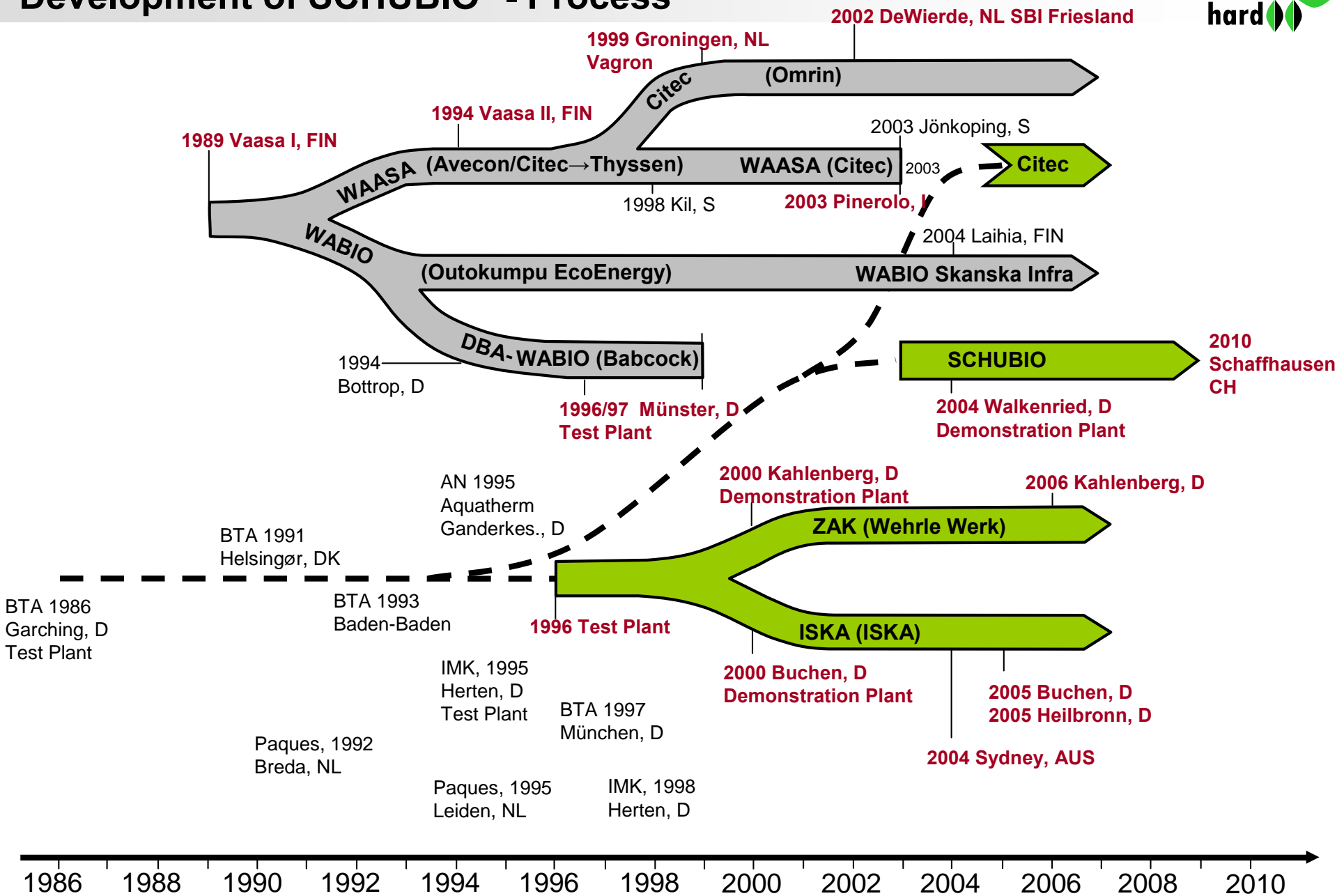

# Development of SCHUBIO® - Process



## First Patent Application SCHUBIO®-Process

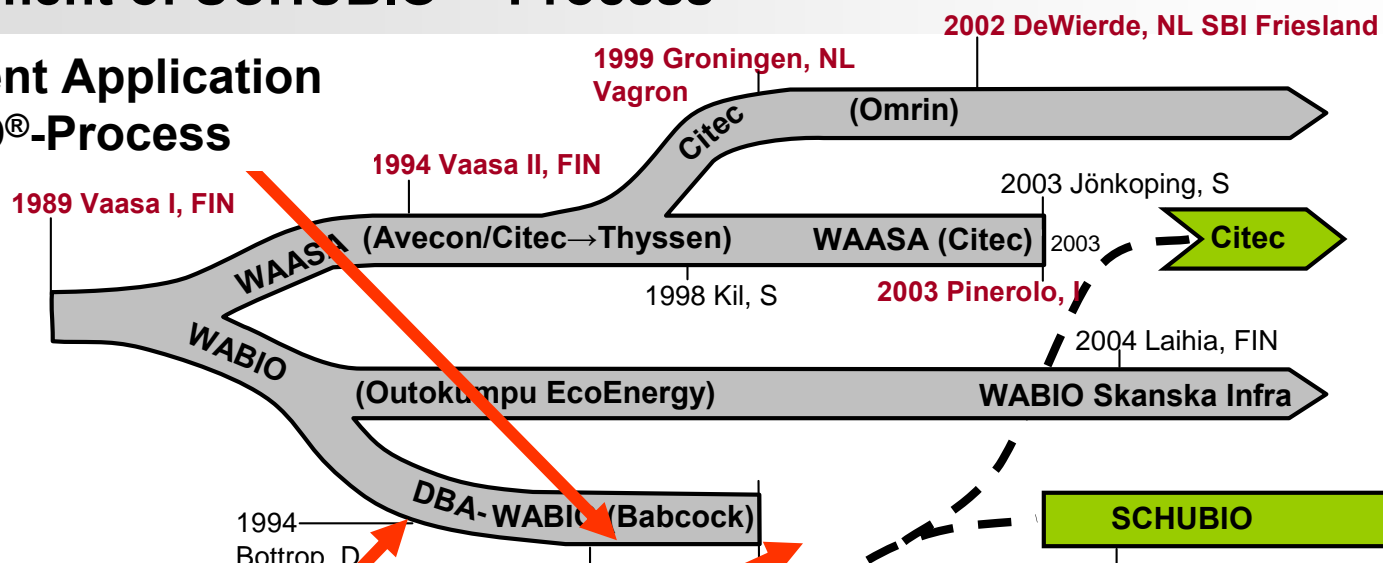

## First wet fermentation of Biowaste in Germany

## Grant Application for SCHUBIO®-Process DBU Deutsche Bundesstiftung Umwelt

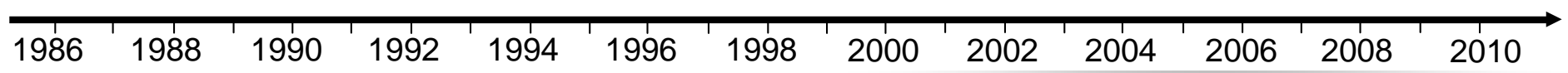
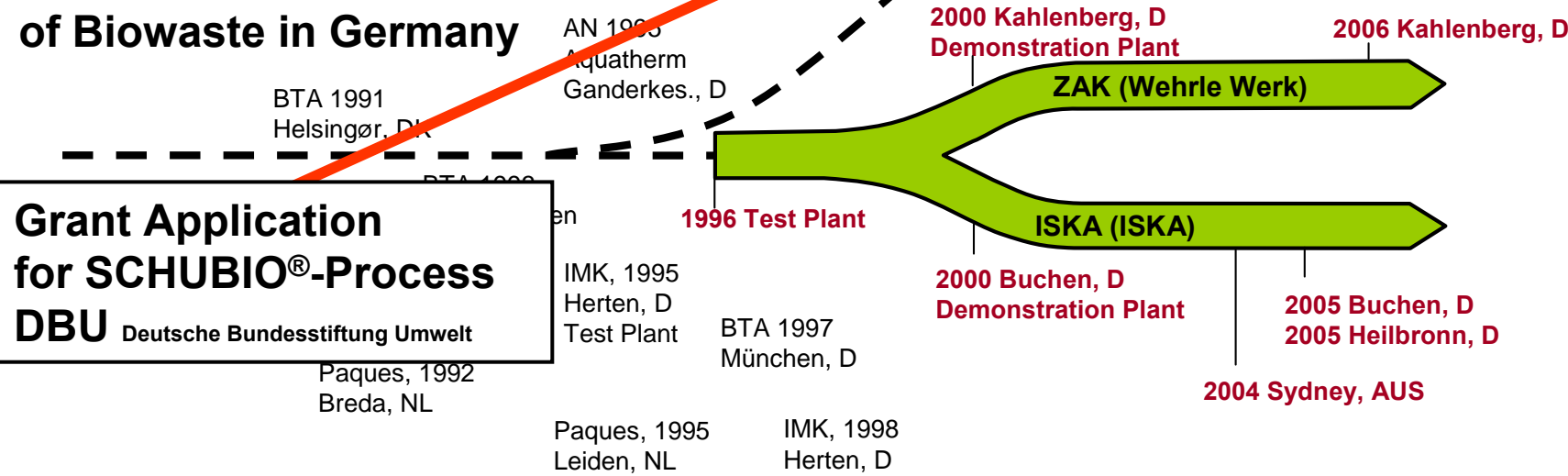

# Development of SCHUBIO

First Patent Application  
SCHUBIO®-Process

First wet fermentation  
of Biowaste in Germany

Grant Application  
for SCHUBIO®-Process  
DBU Deutsche Bundesstiftung Umwelt

## Test Runs Wiefels



## Test Runs Schaffhausen



1989 Vaasa I, FIN

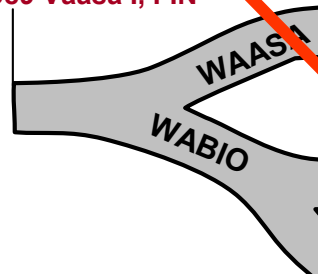

1994  
Bottrop, D

DBA-WABIO (Babcock)

1996/97 Münster, D  
Test Plant

AN 1995  
Aquatherm  
Ganderkes., D

2000 Kahlenberg, D  
Demonstration Plant

ZAK (Wehrle Werk)

2004 Walkenried, D  
Demonstration Plant

2006 Kahlenberg, D

Pilot Phase Walkenried  
2005 – 2007

2005 Buchen, D  
2005 Heilbronn, D

2004 Sydney, AUS

2002 DeWi  
rin)  
2003 Jo  
(Citec)  
2003 Pinerolo, I  
2003  
WABIO

SCHUBIO

2010  
Schaffhausen  
CH

1986 1988 1990 1992

III International Sym



2004 2006 2008 2010





## KBA Hard 1973 - 1988

- 2 Lines MSW Incineration  
**von Roll AG, CH**
- 1 Line Dano Drum  
MSW and Sewage Sludge  
for Compost Production  
**Bühler AG, CH**



## KBA Hard 1988 - 2010

- 1 Line Biowaste  
Composting  
**Bühler AG, CH**
- 1 Line Rotting/Drying  
MSW & Sludge  
RDF Baling and Storage  
**Bühler AG, CH**



## KBA Hard/SCHUBIO® 2010

- 1 Line Biowaste  
SCHUBIO®-Process  
**SCHU AG, CH**
- 1 Line MSW & Sludge  
SCHUBIO® -Process  
RDF Baling and Storage  
**SCHU AG, CH**
- 1 Line Sewage Sludge  
Drying

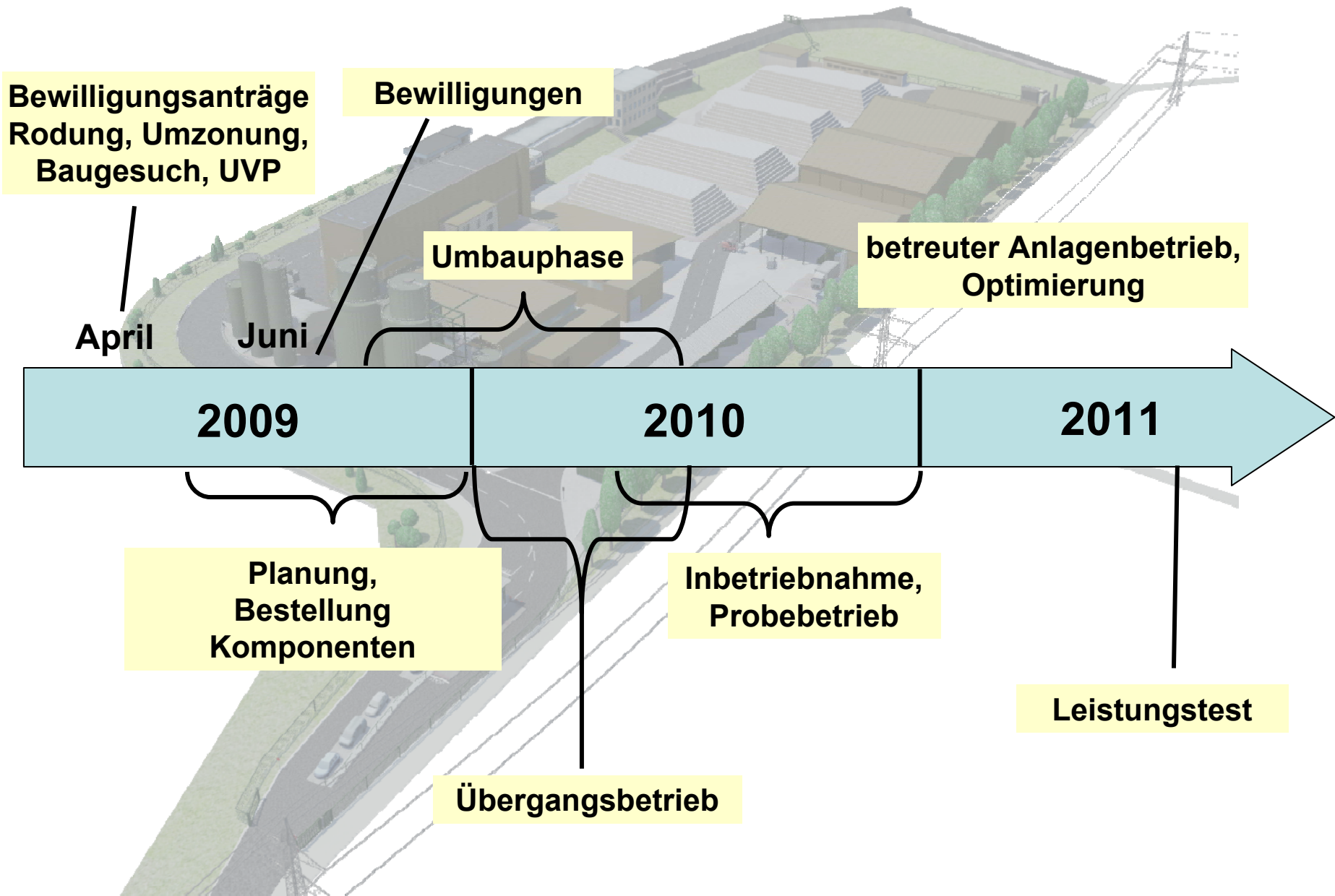

# SCHUBIO-Pilot Plant - 40'- Container – easy shipping

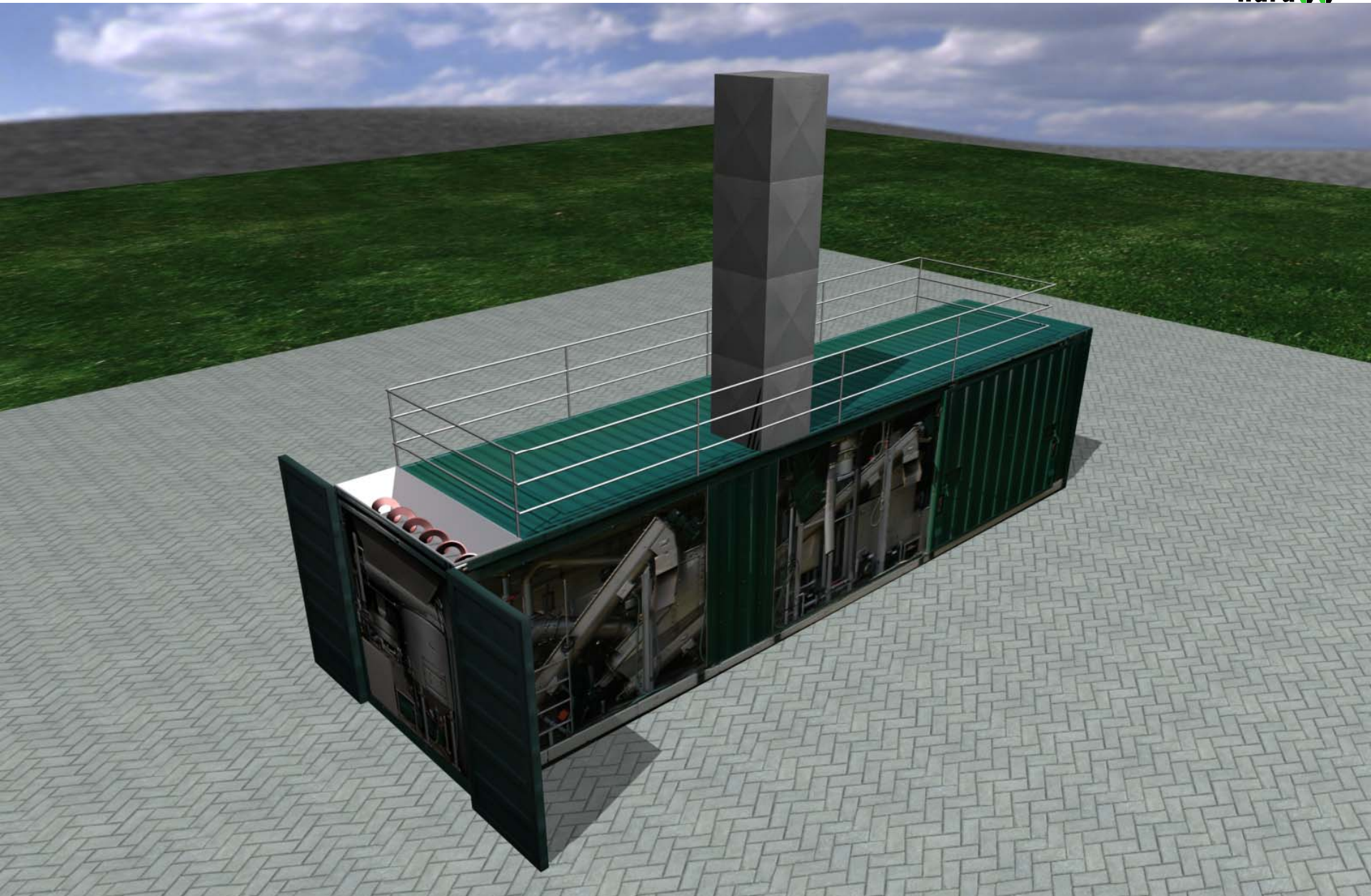

# SCHUBIO-Pilot Plant - 40'- Container – easy shipping





# SCHUBIO®

Schaffhauser Umwelttechnik Biogasverfahren

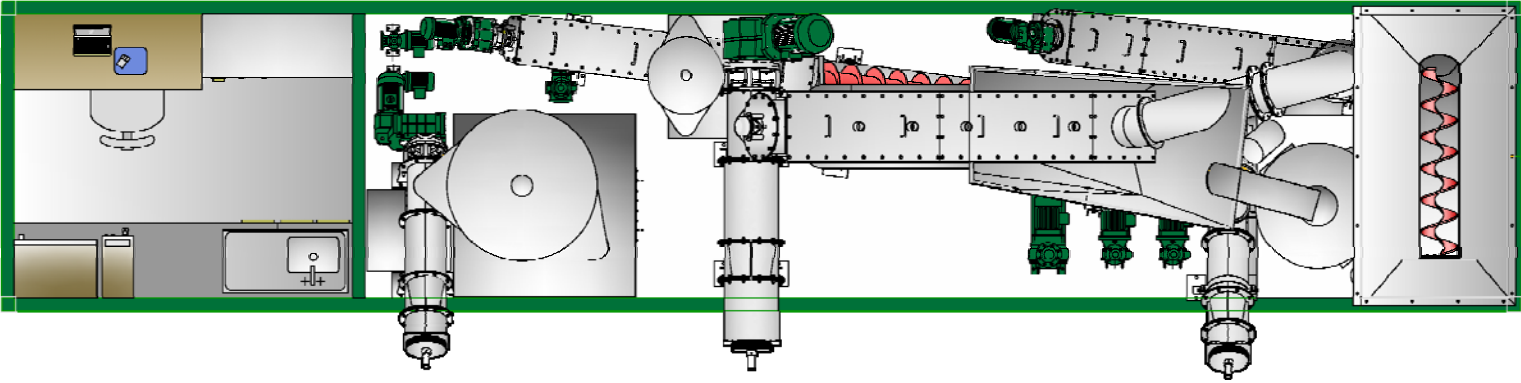
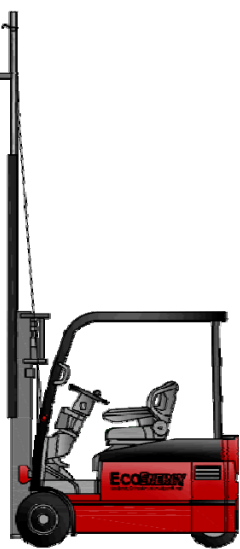
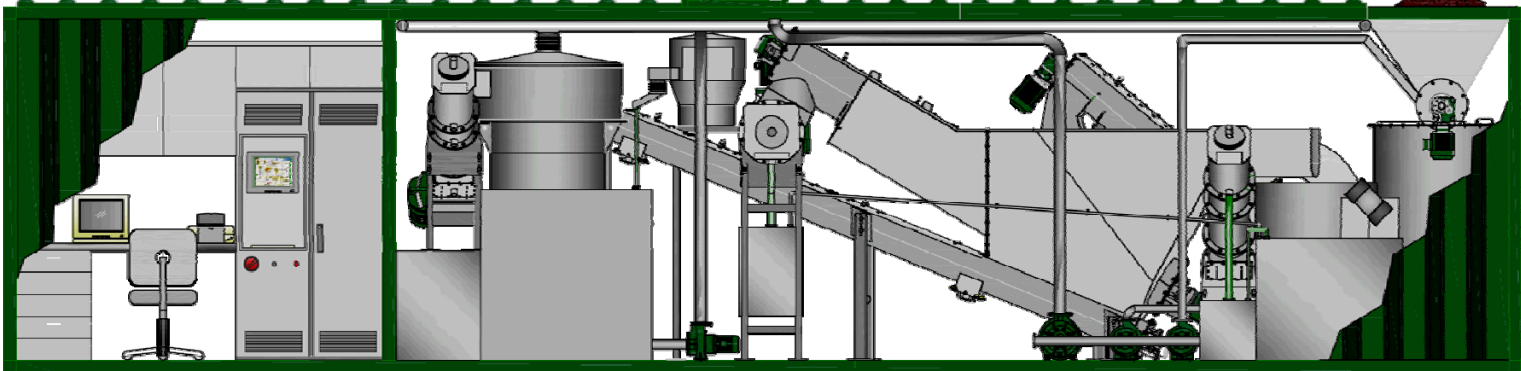
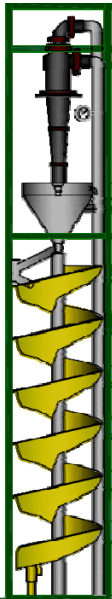

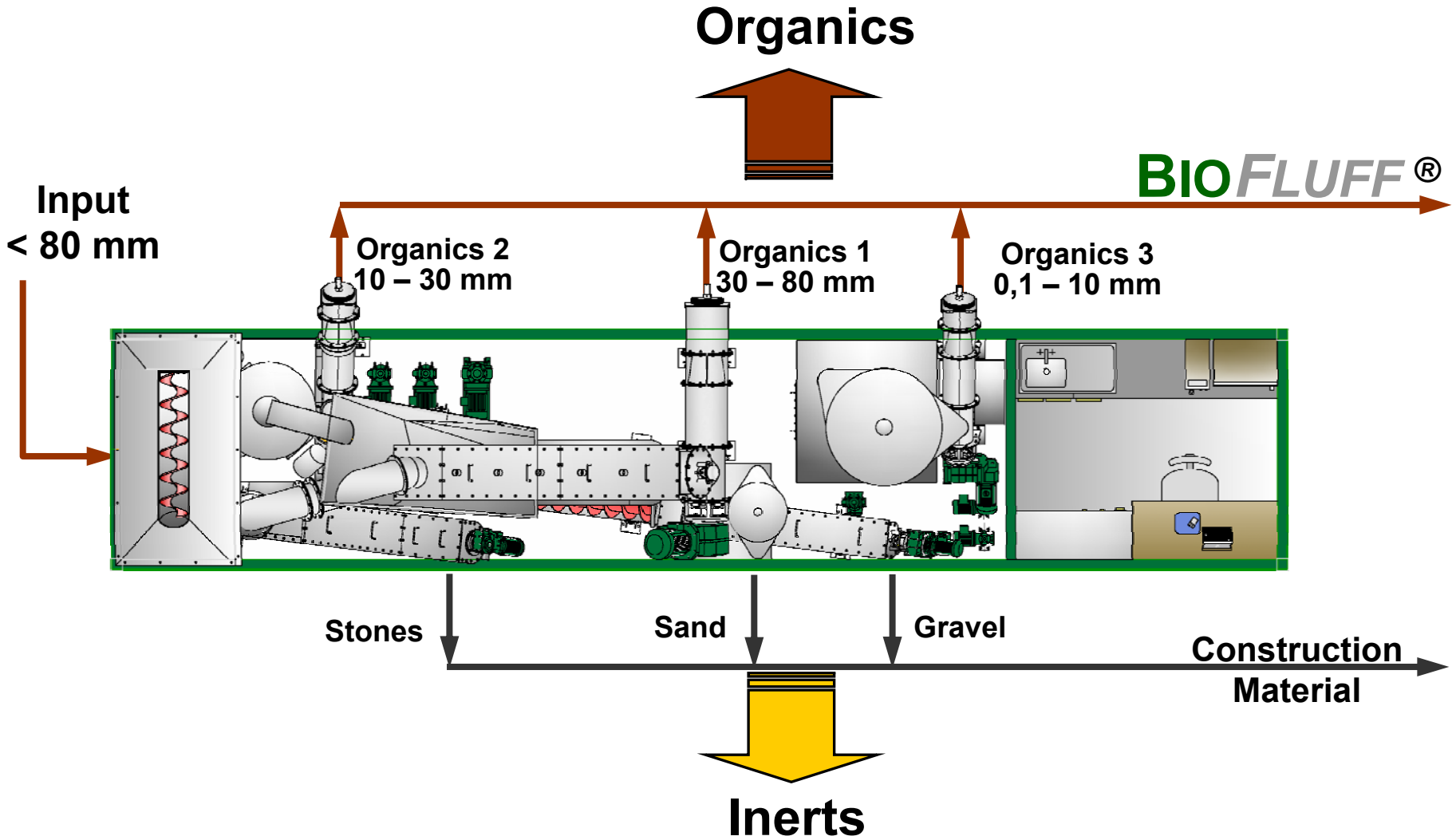

# SCHUBIO®-Pilot Plant – with Biogas Production

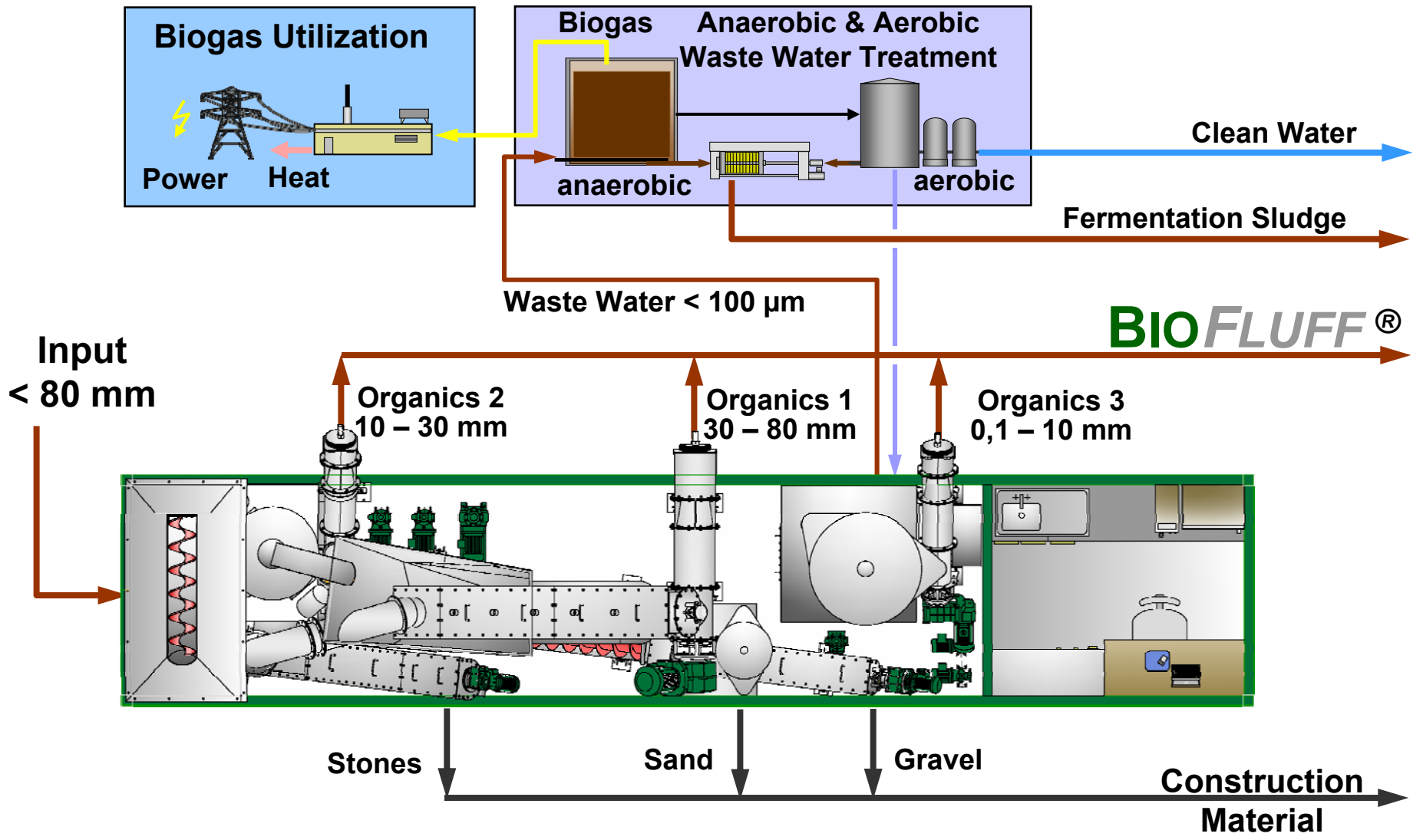

# 4-Stage-wet-Separation

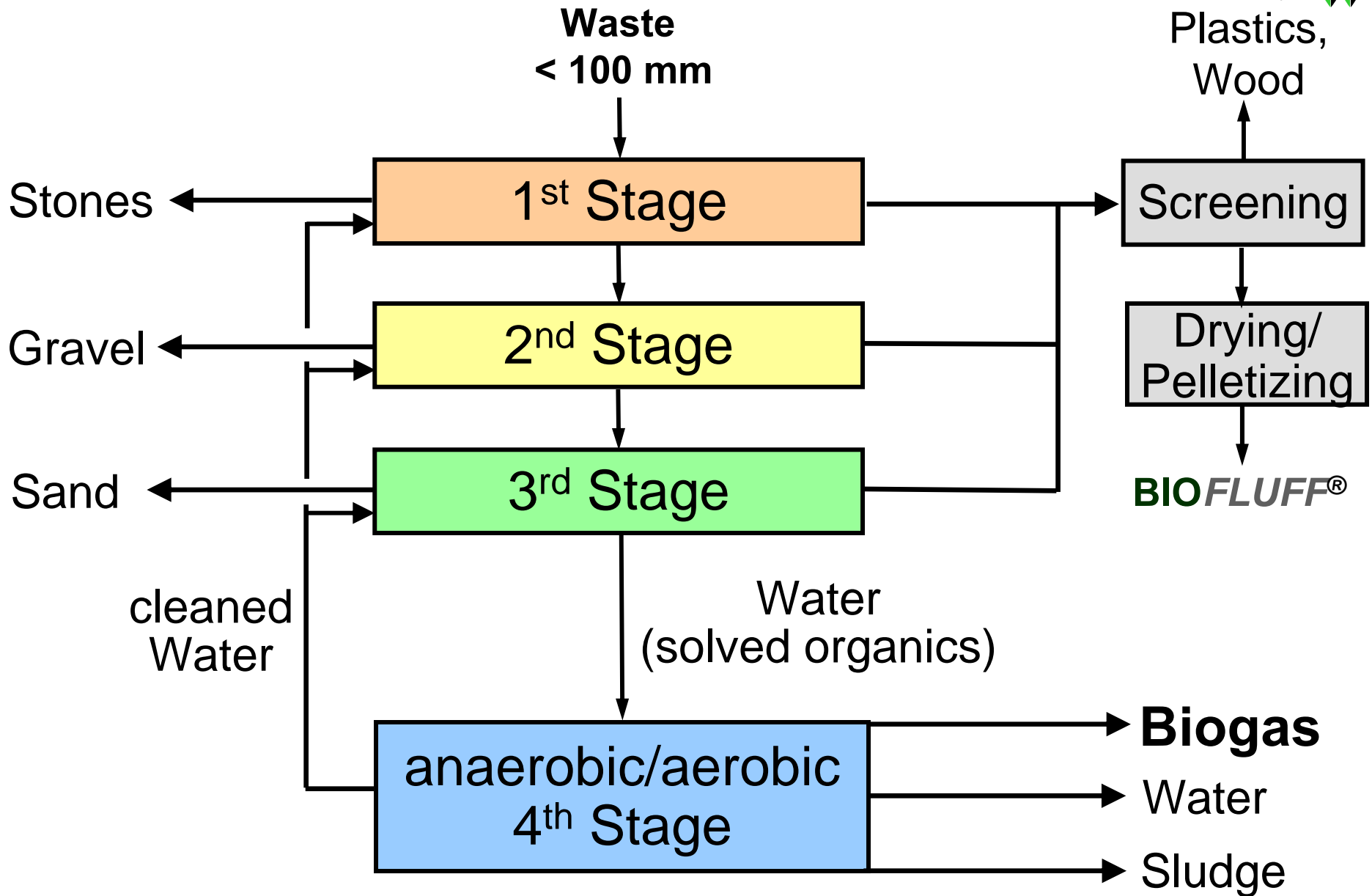

# Pilot Plant SCHUBIO® – Process Flow Diagram

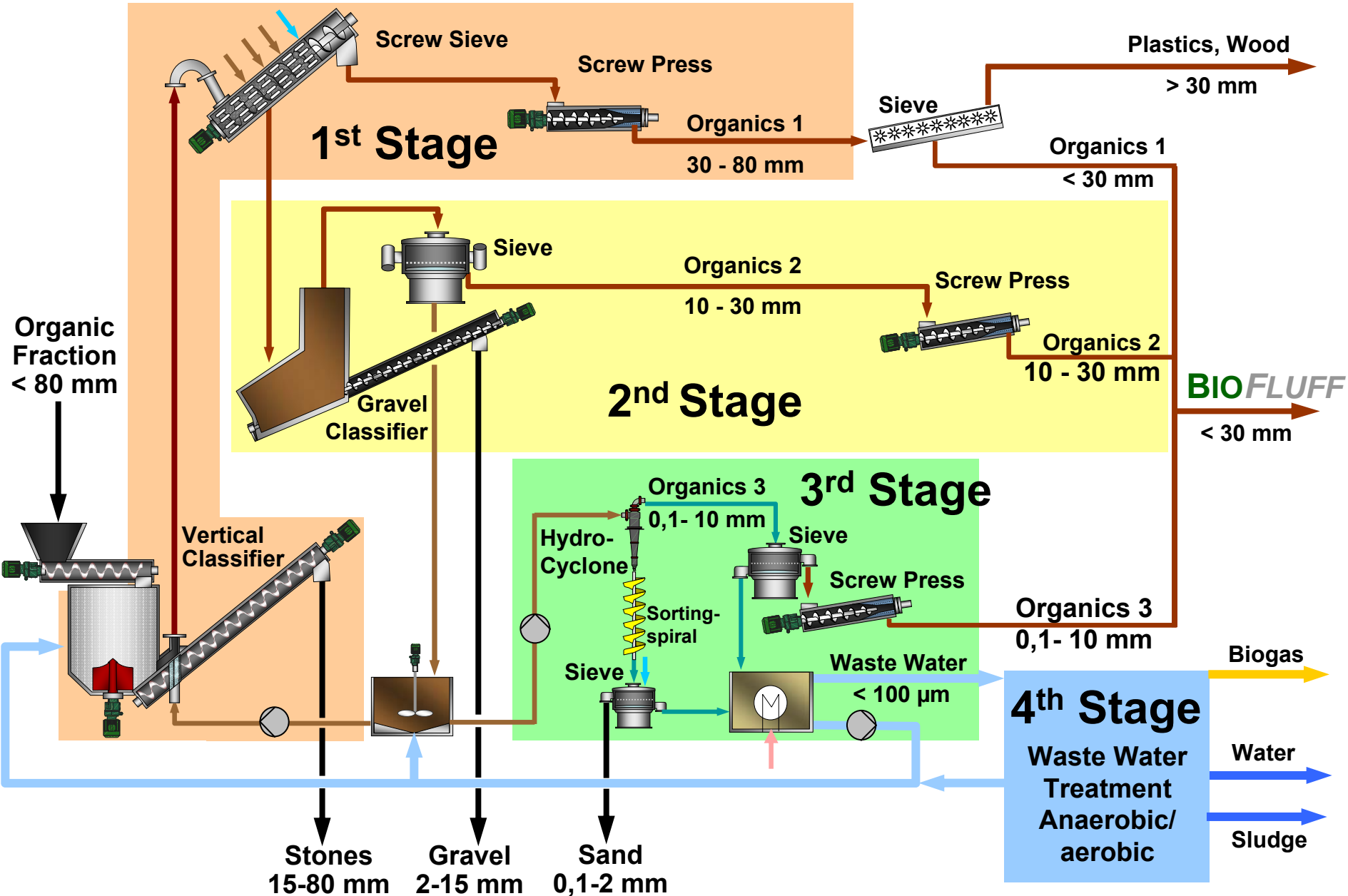



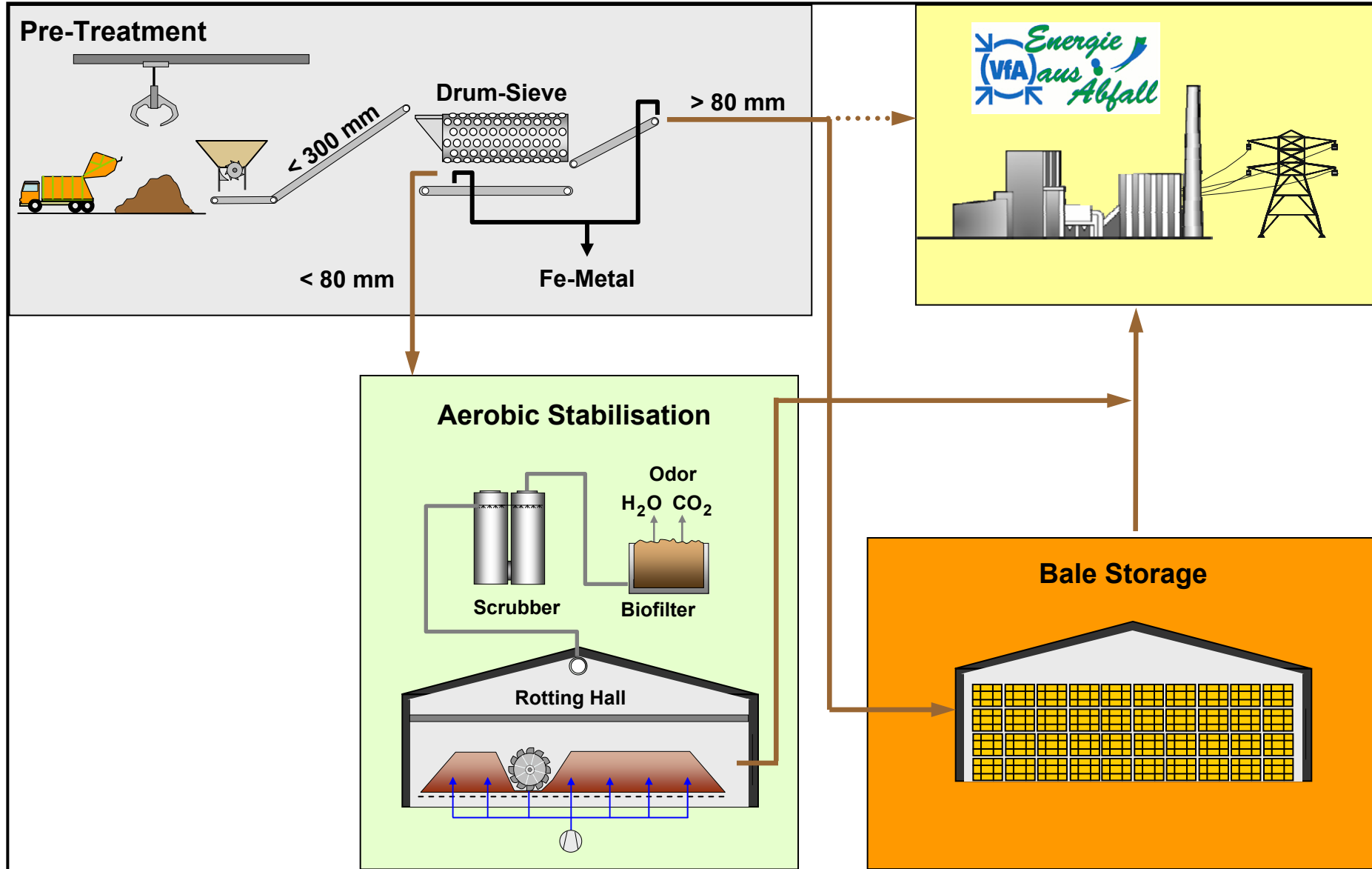

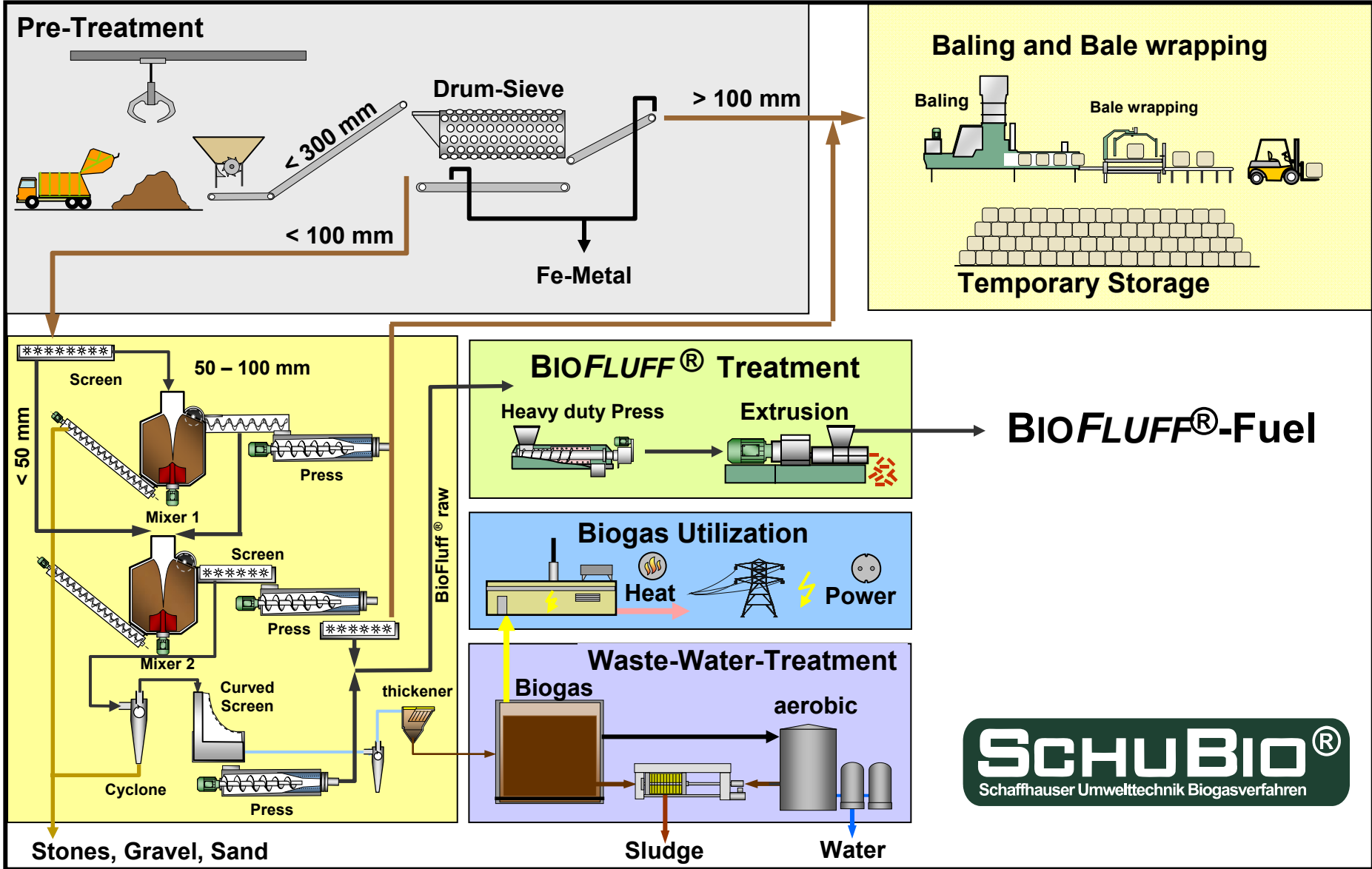



Input  
Σ 39.200 t/a

Biowaste 9.000 t/a  
Wood 900 t/a

MSW 20.000 t/a  
Bulky waste 3.300 t/a

Sewage sludge 6.000 t/a

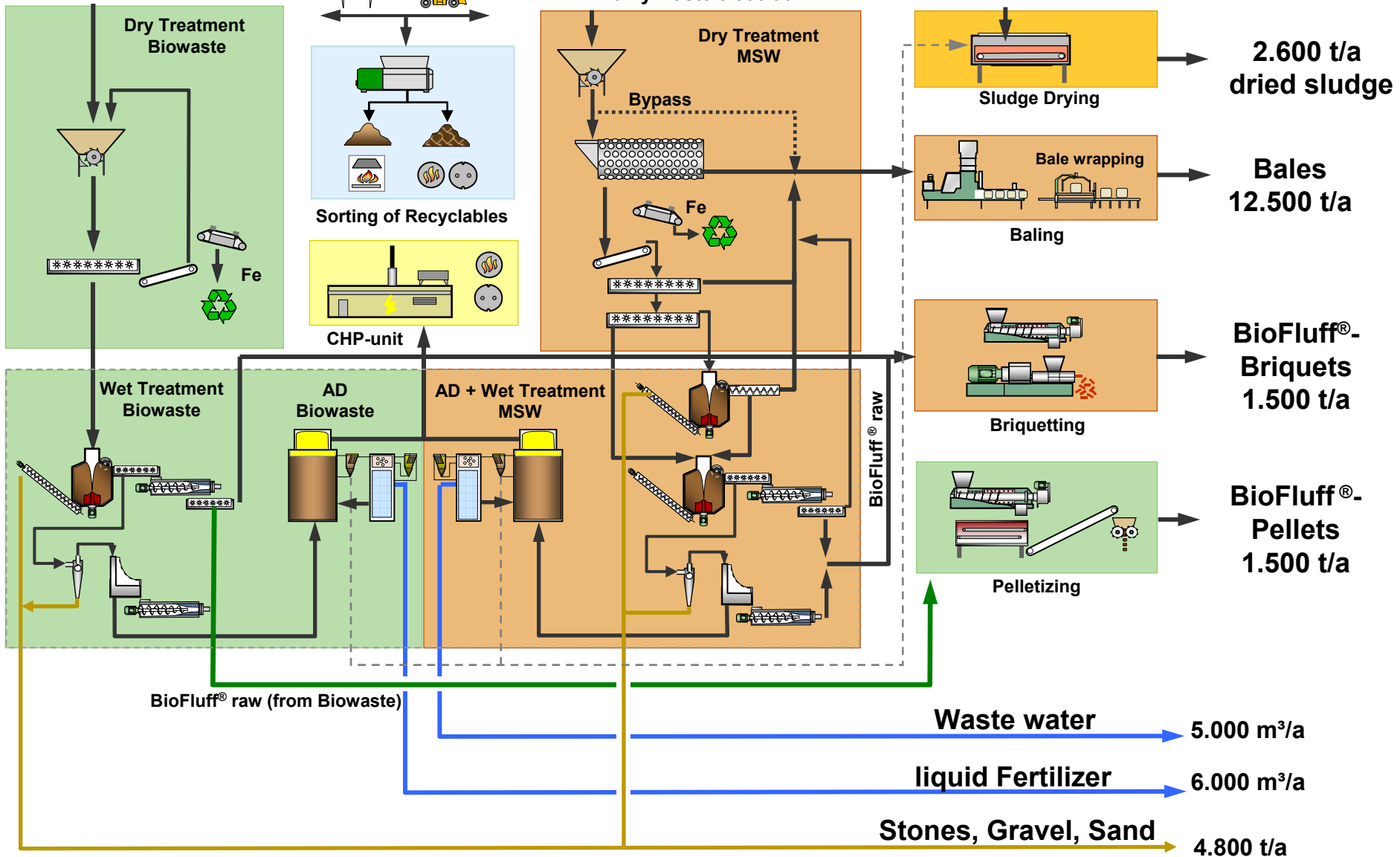





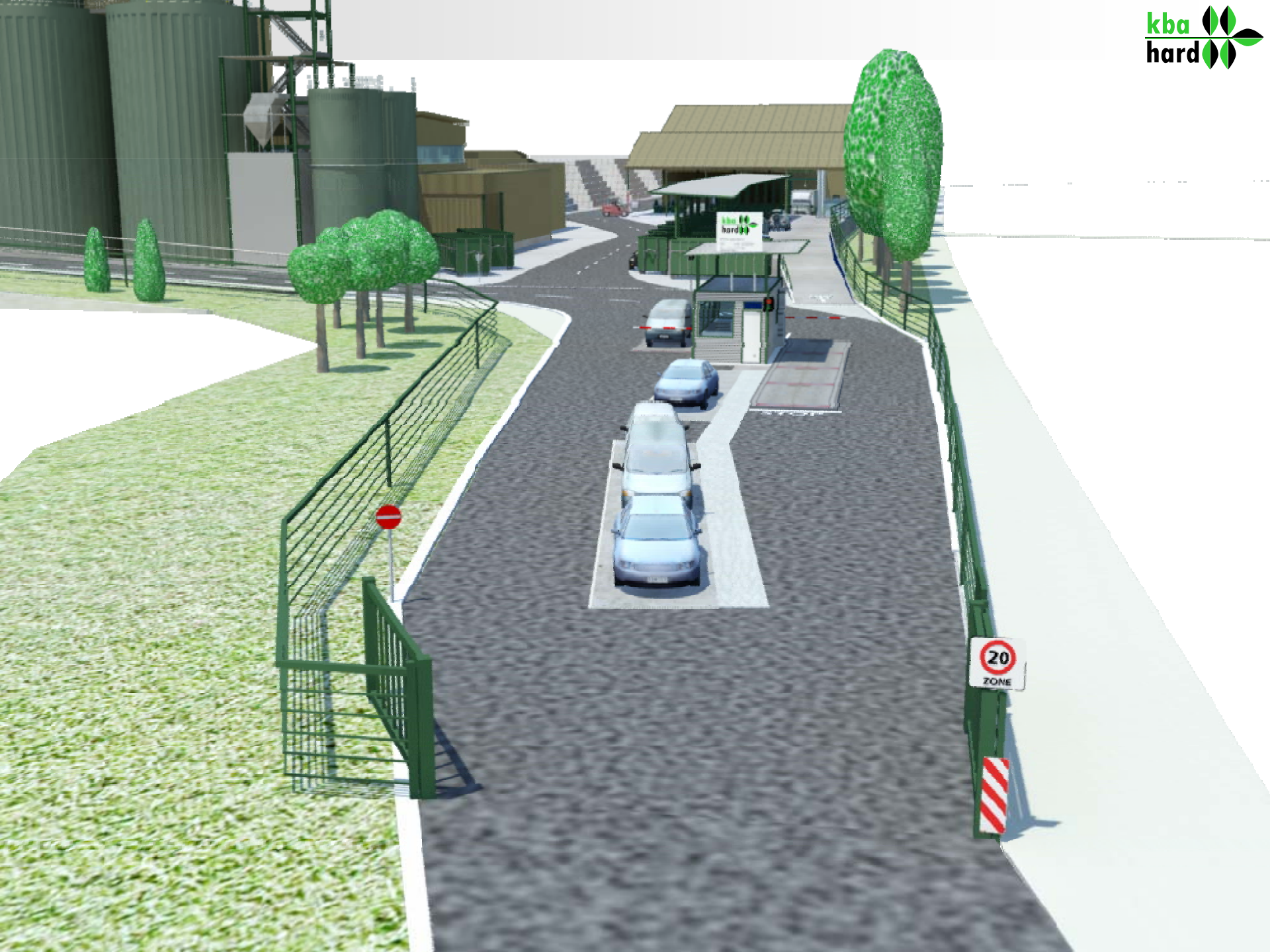













m

**Biowaste**

**MSW**

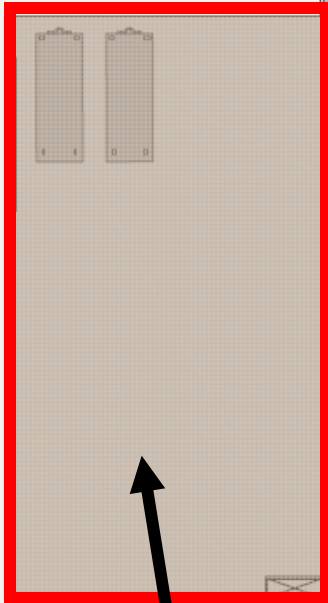

- Sewage Sludge Drying
- BioFluff® Drying

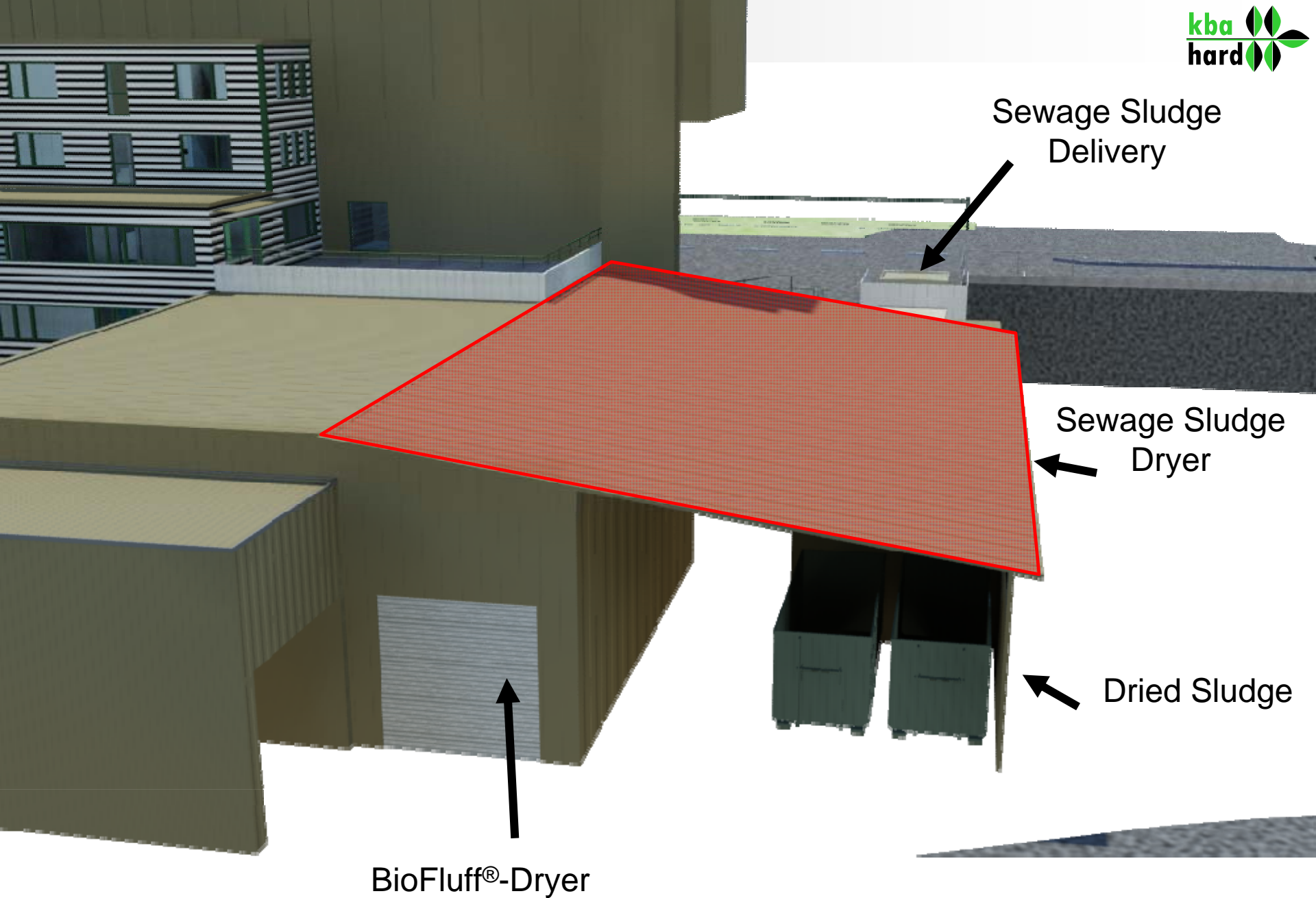

**Thank you for your attention!**

**III International Symposium MBT & MRF**

12.-14.05.2009, Hanover



**Dipl.-Ing. Reinhard Schu**  
**Dipl.-Biol. Kirsten Schu**  
SCHU AG Schaffhauser Umwelttechnik  
Schaffhausen, Switzerland



**SCHU AG**  
Schaffhauser Umwelttechnik